

Community-led monitoring to improve services related to HIV for PLHIV and KP in Cambodia

Chandary Rang,¹ Dalen Nhim,¹ Sopheap Seng,¹ Vora Tim,² Sophal Seum,² Rathana Khun,² Somalay Ouk,³ Tha Ouk,³ Bunthorn Kong³

WEPEE631

BACKGROUND

Gathering evidence from key population (KP) and PLHIV communities about service gaps that can be used to persuade the government and key stakeholders to improve HIV services remains challenging. Constraints include limited capacity, tools, and resources to enable KP/PLHIV representatives to collect and analyze data from communities. To address this need, an online community-led monitoring (CLM) system led by the KP/PLHIV networks was established to serve as a community-friendly data collection tool (Figure 1). KP/PLHIV communities meet and provide feedback systematically every quarter in seven Cambodian provinces with large key populations. The data are automatically incorporated into a dynamic dashboard (PowerBI) that is available to network representatives so they can advocate for service strengthening.

FIGURE 1. The structure of the CLM system

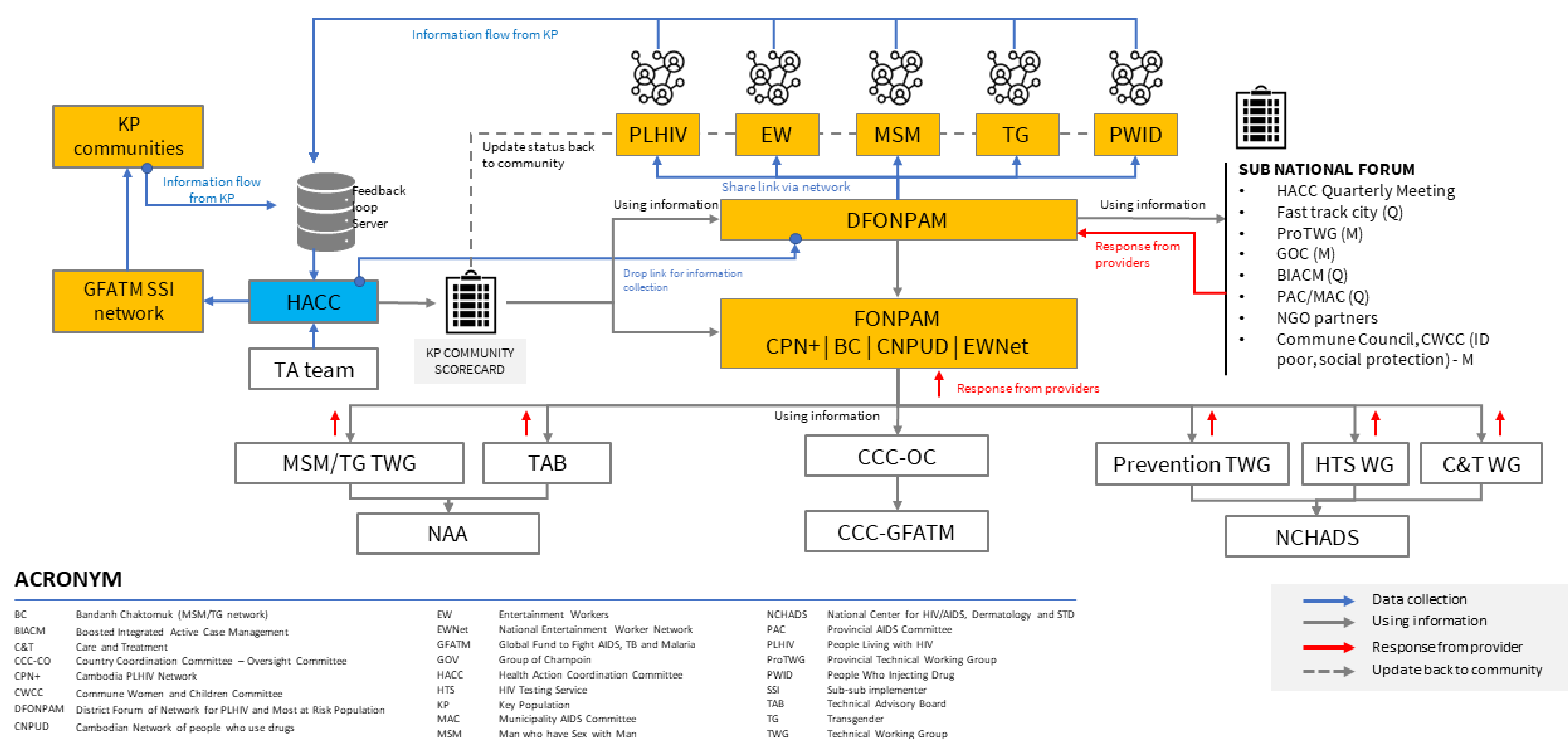

MATERIALS AND METHODS

The CLM tool has seven thematic areas: prevention and HIV testing, pre-exposure prophylaxis, sexually transmitted infections, social protection, care and treatment, gender-based violence, and stigma and discrimination. Every two weeks, a thematic area of CLM is shared with key populations through the Forum of Network of PLHIV and KP (FONPAM) and the District Forum of Network of PLHIV and KP (DFONPAM) so they can provide feedback related to the challenges they face when accessing public services. The KoboToolBox was used to develop the online data collection tool. In addition, the data are automatically analyzed and visualized on the live monitoring dashboard using Microsoft Power BI (Figure 2).

FIGURE 2. The CLM dashboard, which can switch between Khmer and English

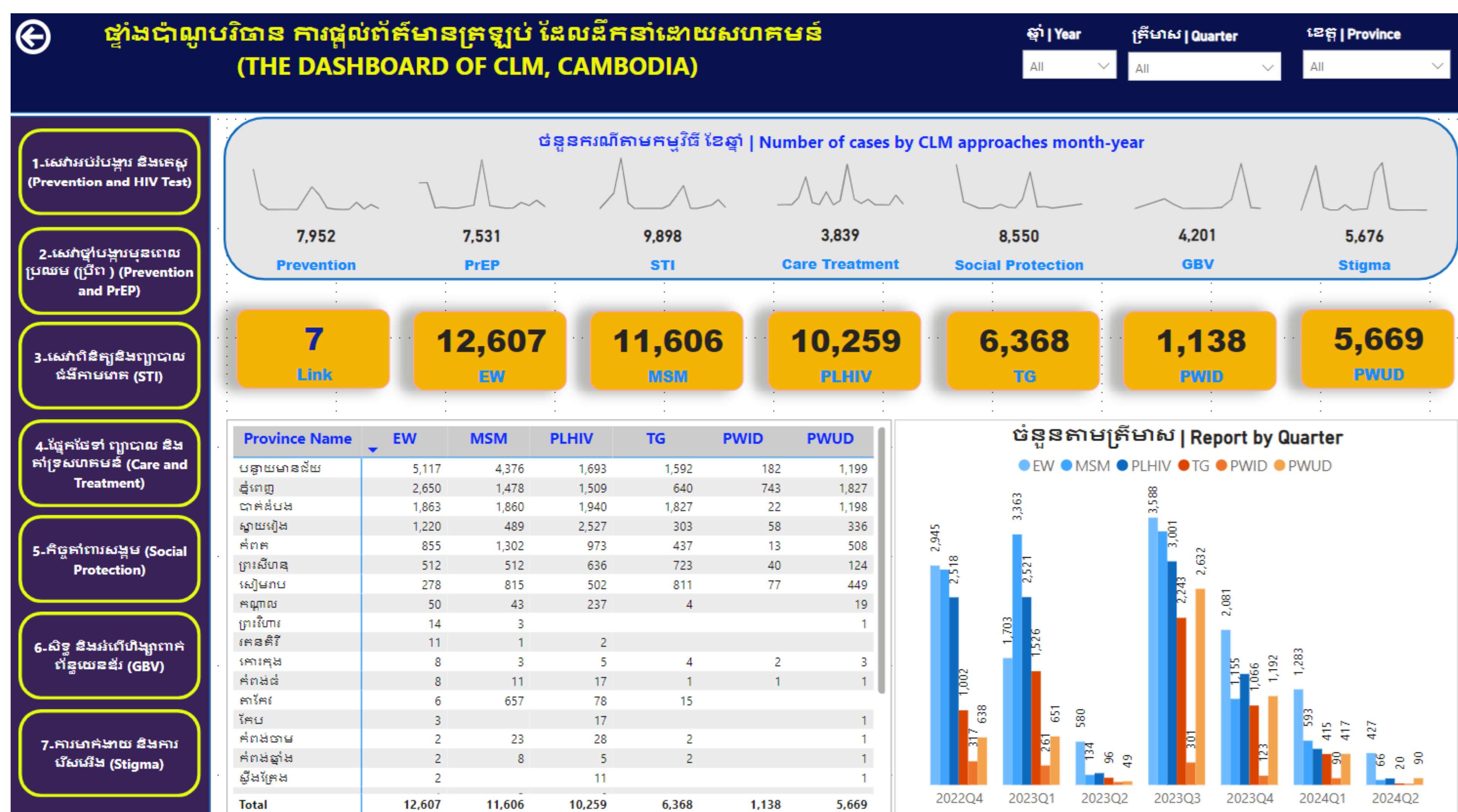

CLM is an effective tool to collect systematic feedback on issues from KP/PLHIV that can be used to improve the quality of services.

RESULTS

In 2023, approximately 3,100 KP/PLHIV respondents provided feedback through the CLM system. KP/PLHIV representatives used the CLM dashboard to present results in several key fora in the country and the region to advocate for better services for KP/PLHIV for both health and non-health issues. One significant CLM result is that the Royal Government of Cambodia now provides universal health insurance coverage via the National Social Security Fund for KPs. The Global Fund approved the request to expand CLM activities from seven to 12 provinces in 2024–2026 based on CLM results.

CONCLUSIONS

CLM is an effective tool for systematically collecting feedback on issues from KP/PLHIV. It produces user-friendly and dynamic dashboards that allow KP/PLHIV representatives to use their data to convince agencies and stakeholders of the need to improve the quality of health and non-health services for KP/PLHIV. KP/PLHIV representatives should scale the CLM system to all 25 provinces.

REFERENCES

FONPAM. Available at: <https://fonpam.info/dashboard>

AUTHOR AFFILIATIONS

- 1 Health Action Coordinating Committee (HACC), Cambodia
- 2 Forum of Network of PLHIV and KP (FONPAM), Cambodia

CONTACT INFORMATION FOR LEAD AUTHOR

Chandary Rang, Technical Advisor, HIV Programs - Cambodia - EpiC Strategic Information, rchandary@fhi360.org

ACKNOWLEDGMENTS

Special thanks are due to the management team of Health Action Coordinating Committee, which provided great coordination with the KP community to implement CLM. We thank UNAIDS, National AIDS Authority, and National Center for HIV AIDS Dermatology and STD for their encouragement and technical support.